

The information provided herein is from CONNFLY Electronic Co., Ltd. and is confidential. Any disclosure to a party other than the recipient is prohibited. The intellectual properties and its rights of CONNFLY Electronic Co., Ltd. are strictly protected. Any modification is strictly prohibited without prior written consent from CONNFLY. All intellectual properties provided herein are for reference purposes only and does not constitute authorization of its use in any format or manner. CONNFLY may enforce its intellectual property rights at its own discretion; failures or delays to exercise such rights does not constitute a waiver of such rights.

1 2 3 4 5 6 7 8

Dept	Qty
DC	1
ED	1
IE	1
ISO	1
PD	1
R&D	1
SD	1
QA	1
QC	1
QE	1

REV.	DESCRIPTION	DRAWN	CHECKED	APPROVED
A	NEW RELEASE	WPY 10/08/24'		

Assembly

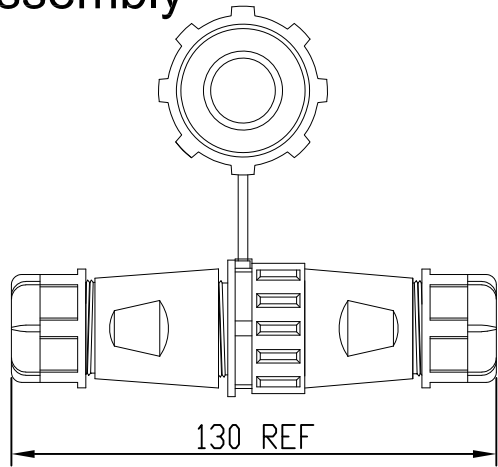

Male

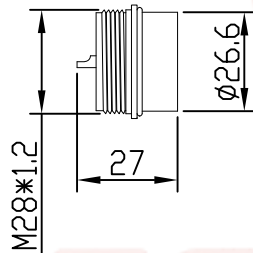
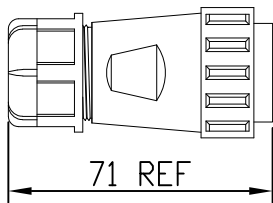

Famale

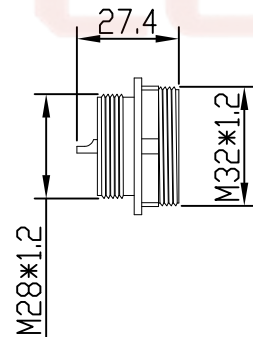
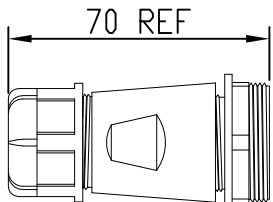

Suitable for $\phi 8-12$ $\phi 12-16$ wires

Note:

1. Rated voltage: 300V-500V
2. Rated current: 5A-45A
3. insulation resistance: 2000M Ω
4. Withstand voltage: 1500V
5. Operating temperature: -30°C to +90°C
6. Wiring method: Welding

Materials:

1. Shell material: PA66
2. Insulation material: PPS
High temperature resistance 260°C
3. Contact material: Copper gold plating

Product Number Code:

DS1110-59-X X X X X

- Install Type
- A: A Type
- Contact Plating
- 8: Gold flash
- Color of nut
- U: Blue
- Color of housing
- B: Black
- No. of Contacts
- 2B 3B 4B 3 5 6 7 9 10 12
- 14 16 19 22 24 26

GENERAL TOLERANCE		ANGLE TOLERANCE	
X.	± 0.60	X.	$\pm 5^\circ$
.X	± 0.38	.X	$\pm 3^\circ$
.XX	± 0.25	.XX	$\pm 2^\circ$

PROJECTION		TITLE	$\phi 28$ waterproof aviation plug docking type
UNITS	mm	SERIES	DS1110-59 Series
SHEET SIZE	A4		

DRAWING TYPE	CUSTOMER		
SCALE	1:1	SHEET	1 OF 1
DRAWING NO.	C-DS1110-59-XXXXX-A		

晨翔电子有限公司
CONNFLY CONNFLY ELECTRONIC CO. LTD

1 2 3 4 5 6 7 8

The information provided herein is from CONNFLY Electronic Co., Ltd. and is confidential. Any disclosure to a party other than the recipient is prohibited. The intellectual properties and its rights are reserved for CONNFLY Electronic Co., Ltd. All intellectual properties provided herein are for reference purposes only and does not constitute authorization of its use in any format or manner. CONNFLY may enforce its intellectual property rights at its own discretion; failures or delays to exercise such rights does not constitute a waiver of such rights.

1 2 3 4 5 6 7 8

REV.	DESCRIPTION	DRAWN	CHECKED	APPROVED
A	NEW RELEASE	WPY 10/08/24'		

Assembly

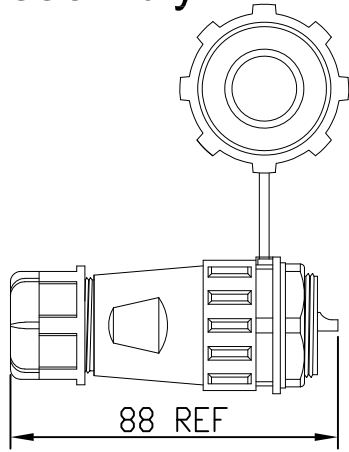

Male

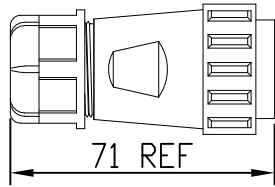

Female

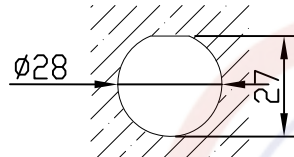
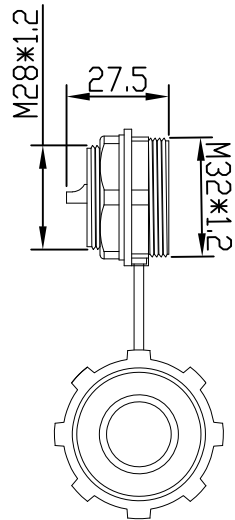

Suggested Panel Opening

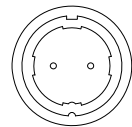
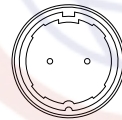
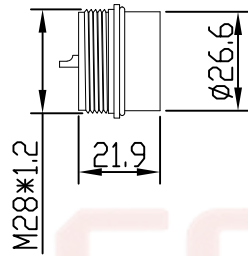

Suitable for $\phi 8-12$ $\phi 12-16$ wires

Note:

1. Rated voltage: 300V-500V
2. Rated current: 5A-45A
3. Insulation resistance: 2000M Ω
4. Withstand voltage: 1500V
5. Operating temperature: -30°C to +90°C
6. Wiring method: Welding

Materials:

1. Shell material: PA66
2. Insulation material: PPS
High temperature resistance 260°C
3. Contact material: Copper gold plating

Product Number Code:

DS1110-59-X X X X X

- Install Type
- B: B Type
- Contact Plating
- 8: Gold flash
- Color of nut
- U: Blue
- Color of housing
- B: Black
- No. of Contacts
- 2B 3B 4B 3 5 6 7 9 10 12
- 14 16 19 22 24 26

GENERAL TOLERANCE		ANGLE TOLERANCE		PROJECTION	TITLE
X.	± 0.60	X.	$\pm 5^\circ$		$\phi 28$ waterproof aviation plug rear nut type
.X	± 0.38	.X	$\pm 3^\circ$	mm	
.XX	± 0.25	.XX	$\pm 2^\circ$	A4	SERIES DS1110-59 Series
DRAWING TYPE		CUSTOMER		晨翔电子有限公司 CONNFLY CONNFLY ELECTRONIC CO. LTD	
SCALE		1:1	SHEET 1 OF 1		
DRAWING NO.		C-DS1110-59-XXXXX-A			

1 2 3 4 5 6 7 8

The information provided herein is from CONNFLY Electronic Co., Ltd. and is confidential. Any disclosure to a party other than the recipient is prohibited. The intellectual properties and its rights are reserved for CONNFLY Electronic Co., Ltd. All intellectual properties provided herein are for reference purposes only and does not constitute authorization of its use in any format or manner. CONNFLY may enforce its intellectual property rights at its own discretion; failures or delays to exercise such rights does not constitute a waiver of such rights.

1 2 3 4 5 6 7 8

Dept	Qty
DC	1
ED	1
IE	1
ISO	1
PD	1
R&D	1
SD	1
QA	1
QC	1
QE	1

REV.	DESCRIPTION	DRAWN	CHECKED	APPROVED
A	NEW RELEASE	WPY 10/08/24'		

Assembly

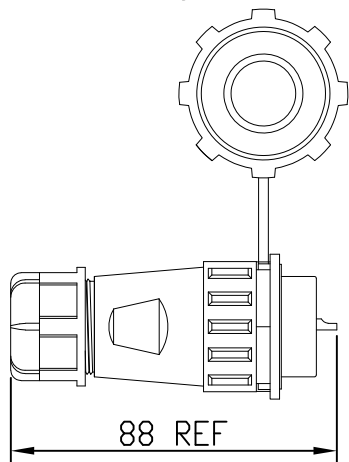

Suitable for $\phi 8-12$ $\phi 12-16$ wires

Note:

1. Rated voltage: 300V-500V
2. Rated current: 5A-45A
3. insulation resistance: 2000M Ω
4. Withstand voltage: 1500V
5. Operating temperature: -30 $^{\circ}$ C to +90 $^{\circ}$ C
6. Wiring method: Welding

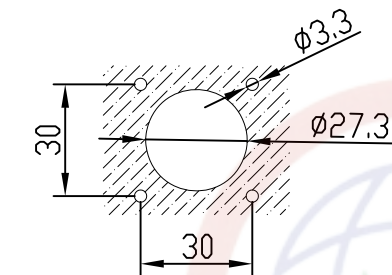

Materials:

1. Shell material: PA66
2. Insulation material: PPS
High temperature resistance 260 $^{\circ}$ C
3. Contact material: Copper gold plating

Product Number Code:

DS1110-59-X X X X X

- Install Type
- C:C Type
- Contact Plating
- 8:Gold flash
- Color of nut
- U:Blue
- Color of housing
- B:Black
- No. of Contacts
- 2B 3B 4B 3 5 6 7 9 10 12
- 14 16 19 22 24 26

Male

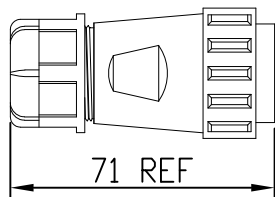

Suggested Panel Opening

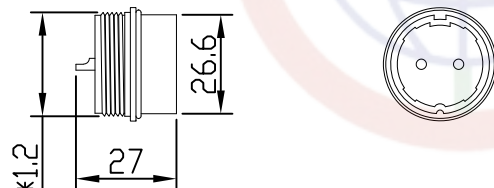

Female

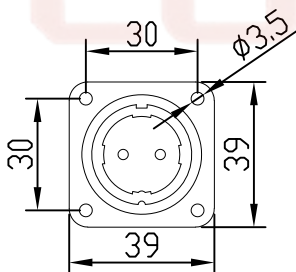
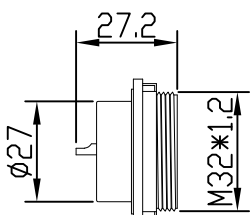

GENERAL TOLERANCE		ANGLE TOLERANCE	
X.	± 0.60	X.	$\pm 5^{\circ}$
.X	± 0.38	.X	$\pm 3^{\circ}$
.XX	± 0.25	.XX	$\pm 2^{\circ}$

PROJECTION		TITLE	$\phi 28$ waterproof aviation plug square disc type
UNITS	mm		
SHEET SIZE	A4	SERIES	DS1110-59 Series

DRAWING TYPE	CUSTOMER		
SCALE	1:1	SHEET	1 OF 1
DRAWING NO.	C-DS1110-59-XXXXX-A		

晨翔电子有限公司
CONNFLY CONNFLY ELECTRONIC CO. LTD

1 2 3 4 5 6 7 8

Dept
Qty

DC 1
ED 1
IE 1
ISO 1
PD 1
R&D 1
SD 1
QA 1
QC 1
QE 1

The information provided herein is from CONNELY Electronic Co., Ltd. and is confidential. Any disclosure to a party other than the recipient is prohibited. The intellectual properties and its rights of CONNELY Electronic Co., Ltd. are strictly protected. All intellectual properties provided herein are for reference purposes only and does not constitute authorization of its use in any format or manner. CONNELY may enforce its intellectual property rights at its own discretion; failures or delays to exercise such rights does not constitute a waiver of such rights.

REV.	DESCRIPTION	DRAWN	CHECKED	APPROVED
A	NEW RELEASE	WPY 10/08/24'		

Solder contact arrangement and spec

No.of Contacts	2B	3B	4B	3	5	6	7	9	10	12
Malc contact face view										
Rated current (A)	45A	45A	45A	25A	25A	25A	25A	10A	10A	10A
Contact diameter	Ø1.5×2	Ø1.5×3	Ø1×4	Ø2.8×3	Ø2.8×5	Ø2.8×6	Ø2.8×7	Ø1.8×9	Ø1.8×10	Ø1.8×12
Wiring method	Welding									
Woring Voltage (AC.V)	500V	500V	500V	400V	400V	400V	400V	400V	400V	400V
Testvoltage(AC.V)	1500V	1500V	1500V	1500V	1500V	1500V	1200V	1200V	1500V	1500V
Contact resistance(mΩ)	0.5mΩ	0.5mΩ	0.5mΩ	1mΩ	1mΩ	1mΩ	1mΩ	2.5mΩ	2.5mΩ	2.5mΩ
Wire Size (mm ² /AWG)	≤2/14	≤2/14	≤0.785/18	≤2/14	≤2/14	≤2/14	≤0.785/18	≤0.785/18	≤0.785/18	≤0.785/18

GENERAL TOLERANCE		ANGLE TOLERANCE	
X.	±0.60	X.	±5°
.X	±0.38	.X	±3°
.XX	±0.25	.XX	±2°
DRAWING TYPE		CUSTOMER	
SCALE	1:1	SHEET	1 OF 1
DRAWING NO.	C-DS1110-59-XXXX-A		

PROJECTION		TITLE	Ø28 Waterproof aviation plug solder series
UNITS	mm	SERIES	DS1110-58 Series
SHEET SIZE	A4		

晨翔电子有限公司
CONNELY CONNELY ELECTRONIC CO. LTD

Dept
Qty

DC 1
ED 1
IE 1
ISO 1
PD 1
R&D 1
SD 1
QA 1
QC 1
QE 1

The information provided herein is from CONNPLY Electronic Co., Ltd. and is confidential. Any disclosure to a party other than the recipient is prohibited. The intellectual properties and its rights of CONNPLY Electronic Co., Ltd. are strictly protected. All intellectual properties provided herein are for reference purposes only and does not constitute authorization of its use in any format or manner. CONNPLY may enforce its intellectual property rights at its own discretion; failures or delays to exercise such rights does not constitute a waiver of such rights.

REV.	DESCRIPTION	DRAWN	CHECKED	APPROVED
A	NEW RELEASE	WPY 10/08/24'		

Solder contact arrangement and spec

No.of Contacts	14	16	19	22	24	26
Male contact face view						
Rated current (A)	10A	10A	5A	5A	5A	5A
Contact diameter	Ø1.8×14	Ø1.8×16	Ø1×19	Ø1×22	Ø1×24	Ø1×26
Wiring method	Welding					
Woring Voltage (AC.V)	400V	400V	300V	300V	300V	300V
Testvoltage (AC.V)	1500V	1500V	1500V	1500V	1500V	1500V
Contact resistance (mΩ)	2.5mΩ	2.5mΩ	5mΩ	5mΩ	5mΩ	5mΩ
Wire Size (mm ² /AWG)	≤2/14	≤2/14	≤0.785/18	≤0.785/18	≤0.785/18	≤0.785/18

GENERAL TOLERANCE		ANGLE TOLERANCE	
X.	±0.60	X.	±5°
.X	±0.38	.X	±3°
.XX	±0.25	.XX	±2°
DRAWING TYPE		CUSTOMER	
SCALE	1:1	SHEET	1 OF 1
DRAWING NO.	C-DS1110-59-XXXXX-A		

PROJECTION		TITLE	Ø28 Waterproof aviation plug solder series
UNITS	mm	SERIES	DS1110-59 Series
SHEET SIZE	A4		

晨翔电子有限公司
CONNPLY CONNPLY ELECTRONIC CO. LTD